

# RS154 4-to-16 Line Decoder/Demultiplexer

## 1 FEATURES

- **Decodes 4 Binary-Coded Inputs Into 16 Mutually-Exclusive Outputs**
- **Operating Voltage Range: 1.65V to 5.5V**
- **Low Power**
- **Inputs Accept Voltage to 5.5V**
- **Operating Temperature Range: -40°C to +125°C**
- **PACKAGES: TSSOP24**

## 2 APPLICATIONS

- **Power Infrastructure**
- **Factory Automation**

## 3 DESCRIPTIONS

The RS154 is a 4-to-16 line decoder/demultiplexer. It decodes four binary weighted address inputs (A0 to A3) to sixteen mutually exclusive outputs ( $\overline{Y0}$  to  $\overline{Y15}$ ).

The RS154 features two input enable ( $\overline{E0}$  and  $\overline{E1}$ ) inputs. A HIGH on either of the input enables forces the outputs HIGH. The device can be used as a 1-to-16 demultiplexer by using one of the enable inputs as the multiplexed data input. When the other enable input is LOW the addressed output will follow the state of the applied data.

The RS154 is available in Green TSSOP24 packages. It operates over an ambient temperature range of -40°C to +125°C.

### Device Information <sup>(1)</sup>

PART NUMBER	PACKAGE	BODY SIZE (NOM)
RS154	TSSOP24	7.80mm×4.40mm

(1) For all available packages, see the orderable addendum at the end of the data sheet.

## 4 Functional Block Diagram

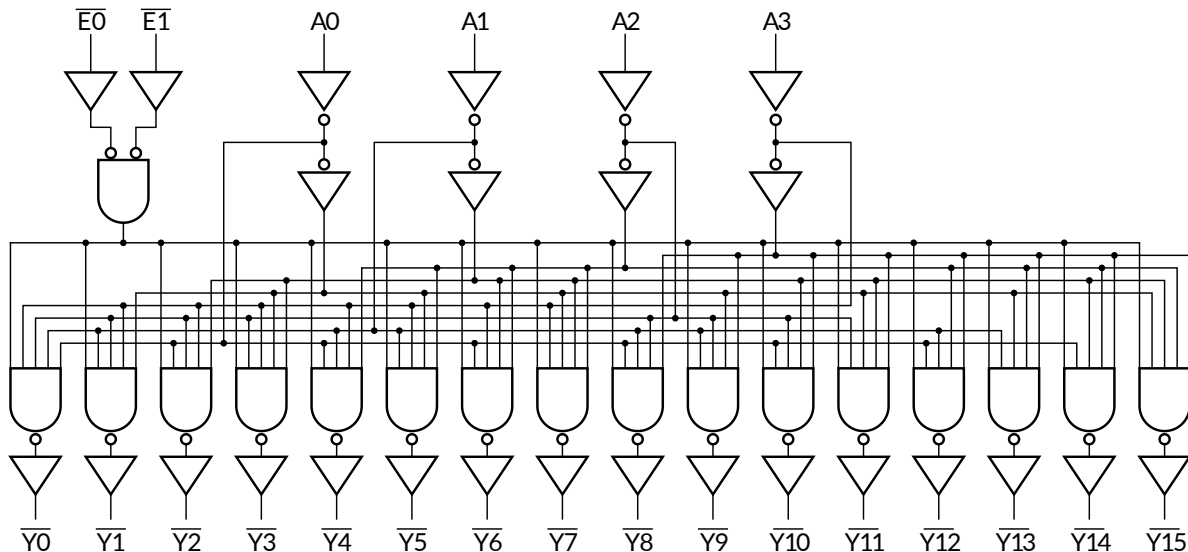

## Table of Contents

<b>1 FEATURES</b> .....	1
<b>2 APPLICATIONS</b> .....	1
<b>3 DESCRIPTIONS</b> .....	1
<b>4 Functional Block Diagram</b> .....	1
<b>5 Revision History</b> .....	3
<b>6 PACKAGE/ORDERING INFORMATION</b> <sup>(1)</sup> .....	4
<b>7 PIN CONFIGURATIONS</b> .....	5
7.1 PIN DESCRIPTION .....	5
7.2 Device Function Table .....	6
<b>8 SPECIFICATIONS</b> .....	7
8.1 Absolute Maximum Ratings .....	7
8.2 ESD Ratings .....	7
8.3 Recommended Operating Conditions .....	7
8.4 ELECTRICAL CHARACTERISTICS .....	8
8.5 Dynamic Characteristics .....	9
<b>9 Parameter Measurement Information</b> .....	10
<b>10 PACKAGE OUTLINE DIMENSIONS</b> .....	12
<b>11 TAPE AND REEL INFORMATION</b> .....	13

## 5 Revision History

Note: Page numbers for previous revisions may differ from page numbers in the current version.

VERSION	Change Date	Change Item
A.0	2024/04/18	Preliminary version completed
A.1	2024/04/29	Initial version completed

**6 PACKAGE/ORDERING INFORMATION <sup>(1)</sup>**

<b>PRODUCT</b>	<b>ORDERING NUMBER</b>	<b>TEMPERATURE RANGE</b>	<b>PACKAGE LEAD</b>	<b>PACKAGE MARKING <sup>(2)</sup></b>	<b>MSL<sup>(3)</sup></b>	<b>PACKAGE OPTION</b>
RS154	RS154XTSS24	-40°C ~+125°C	TSSOP24	RS154	MSL3	Tape and Reel, 4000

## NOTE:

- (1) This information is the most current data available for the designated devices. This data is subject to change without notice and revision of this document. For browser-based versions of this data sheet, refer to the right-hand navigation.
- (2) There may be additional marking, which relates to the lot trace code information (data code and vendor code), the logo or the environmental category on the device.
- (3) MSL, The Moisture Sensitivity Level rating according to the JEDEC industry standard classifications.

## 7 PIN CONFIGURATIONS

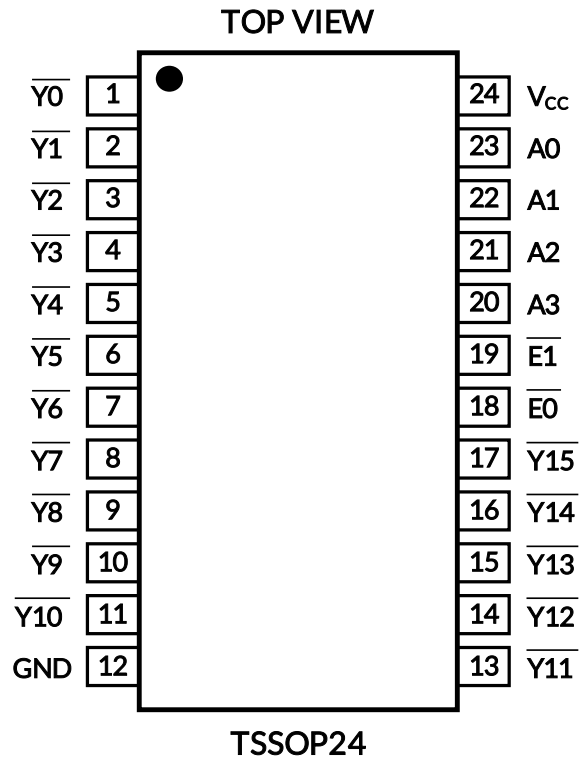

### 7.1 PIN DESCRIPTION

SYMBOL	PIN	DESCRIPTION
	TSSOP14	
$\overline{Y0}, \overline{Y1}, \overline{Y2}, \overline{Y3}, \overline{Y4}, \overline{Y5}, \overline{Y6}, \overline{Y7}, \overline{Y8}, \overline{Y9}, \overline{Y10}, \overline{Y11}, \overline{Y12}, \overline{Y13}, \overline{Y14}, \overline{Y15}$	1, 2, 3, 4, 5, 6, 7, 8, 9, 10, 11, 13, 14, 15, 16, 17	Data output (active LOW)
GND	12	Ground (0 V)
$\overline{E0}, \overline{E1}$	18, 19	Enable output (active LOW)
A0, A1, A2, A3	23, 22, 21, 20	Address input
V <sub>CC</sub>	24	Supply voltage

**7.2 Device Function Table**

Input					Output																		
$\overline{E0}$	$\overline{E1}$	A0	A1	A2	A3	$\overline{Y0}$	$\overline{Y1}$	$\overline{Y2}$	$\overline{Y3}$	$\overline{Y4}$	$\overline{Y5}$	$\overline{Y6}$	$\overline{Y7}$	$\overline{Y8}$	$\overline{Y9}$	$\overline{Y10}$	$\overline{Y11}$	$\overline{Y12}$	$\overline{Y13}$	$\overline{Y14}$	$\overline{Y15}$		
H	H	X	X	X	X	H	H	H	H	H	H	H	H	H	H	H	H	H	H	H	H	H	
H	L	X	X	X	X	H	H	H	H	H	H	H	H	H	H	H	H	H	H	H	H	H	
L	H	X	X	X	X	H	H	H	H	H	H	H	H	H	H	H	H	H	H	H	H	H	
L	L	L	L	L	L	L	H	H	H	H	H	H	H	H	H	H	H	H	H	H	H	H	
		H	L	L	L	H	L	H	H	H	H	H	H	H	H	H	H	H	H	H	H	H	H
		L	H	L	L	H	H	L	H	H	H	H	H	H	H	H	H	H	H	H	H	H	H
		H	H	L	L	H	H	H	L	H	H	H	H	H	H	H	H	H	H	H	H	H	H
		L	L	H	L	H	H	H	H	L	H	H	H	H	H	H	H	H	H	H	H	H	H
		H	L	H	L	H	H	H	H	H	L	H	H	H	H	H	H	H	H	H	H	H	H
		L	H	H	L	H	H	H	H	H	H	L	H	H	H	H	H	H	H	H	H	H	H
		H	H	H	L	H	H	H	H	H	H	H	H	L	H	H	H	H	H	H	H	H	H
		L	L	L	H	H	H	H	H	H	H	H	H	H	L	H	H	H	H	H	H	H	H
		H	L	L	H	H	H	H	H	H	H	H	H	H	H	L	H	H	H	H	H	H	H
		L	H	L	H	H	H	H	H	H	H	H	H	H	H	H	L	H	H	H	H	H	H
		H	H	L	H	H	H	H	H	H	H	H	H	H	H	H	H	L	H	H	H	H	H
		L	L	H	H	H	H	H	H	H	H	H	H	H	H	H	H	H	L	H	H	H	H
		H	L	H	H	H	H	H	H	H	H	H	H	H	H	H	H	H	H	L	H	H	H
		L	H	H	H	H	H	H	H	H	H	H	H	H	H	H	H	H	H	H	L	H	H
H	H	H	H	H	H	H	H	H	H	H	H	H	H	H	H	H	H	H	H	H	L		

(1) H = HIGH voltage level; L = LOW voltage level; X=don't care

## 8 SPECIFICATIONS

### 8.1 Absolute Maximum Ratings

Over operating free-air temperature range (unless otherwise noted) <sup>(1)</sup>

SYMBOL	PARAMETER	CONDITIONS	MIN	MAX	UNIT
V <sub>CC</sub>	Supply Voltage Range		-0.5	6.5	V
I <sub>IK</sub>	Input Clamp Current	V <sub>I</sub> < -0.5 V or V <sub>I</sub> > V <sub>CC</sub> + 0.5 V <sup>(2)</sup>		±20	mA
I <sub>OK</sub>	Output Clamp Current	V <sub>O</sub> < -0.5 V or V <sub>O</sub> > V <sub>CC</sub> + 0.5 V <sup>(2)</sup>		±20	mA
I <sub>O</sub>	Output Current	-0.5 V < V <sub>O</sub> < V <sub>CC</sub> + 0.5 V <sup>(2)</sup>		±25	mA
I <sub>CC</sub>	Supply Current			50	mA
I <sub>GND</sub>	Ground Current			-50	mA
θ <sub>JA</sub>	Package thermal impedance <sup>(3)</sup>	TSSOP24		35	°C/W
T <sub>stg</sub>	Storage Temperature		-65	150	°C
P <sub>tot</sub>	Total Power Dissipation	T <sub>amb</sub> = -40°C to +125°C		500	mW

(1) Stresses beyond those listed under Absolute Maximum Ratings may cause permanent damage to the device. These are stress ratings only, which do not imply functional operation of the device at these or any other conditions beyond those indicated under Recommended Operating Conditions. Exposure to absolute-maximum-rated conditions for extended periods may affect device reliability.

(2) The input and output voltage ratings may be exceeded if the input and output current ratings are observed.

(3) The package thermal impedance is calculated in accordance with JESD-51.

### 8.2 ESD Ratings

The following ESD information is provided for handling of ESD-sensitive devices in an ESD protected area only.

		VALUE	UNIT
V <sub>(ESD)</sub>	Electrostatic discharge	Human-Body Model (HBM)	±2000
		Charged-Device Model (CDM)	±1000
		Machine Model (MM)	±200



#### ESD SENSITIVITY CAUTION

ESD damage can range from subtle performance degradation to complete device failure. Precision integrated circuits may be more susceptible to damage because very small parametric changes could cause the device not to meet its published specifications.

### 8.3 Recommended Operating Conditions

Voltages are reference to GND (ground=0 V).

SYMBOL	PARAMETER	CONDITIONS	RS154			UNIT
			MIN	TYP	MAX	
V <sub>CC</sub>	Supply Voltage		1.65	5.0	5.5	V
V <sub>I</sub>	Input Voltage		0		V <sub>CC</sub>	V
V <sub>O</sub>	Output Voltage		0		V <sub>CC</sub>	V
T <sub>amb</sub>	Ambient Temperature		-40	25	125	°C
Δt/ΔV	Input Transition Rise and Fall Rate	V <sub>CC</sub> = 2.0 V			625	ns/V
		V <sub>CC</sub> = 4.5 V		1.67	139	ns/V
		V <sub>CC</sub> = 5.5 V			83	ns/V

## 8.4 ELECTRICAL CHARACTERISTICS

At recommended operating conditions; voltages are referenced to GND (ground = 0 V).

SYMBOL	PARAMETER	CONDITIONS	25°C			-40°C to +85°C		-40°C to +125°C		UNIT
			MIN <sup>(1)</sup>	TYP <sup>(2)</sup>	MAX <sup>(1)</sup>	MIN <sup>(1)</sup>	MAX <sup>(1)</sup>	MIN <sup>(1)</sup>	MAX <sup>(1)</sup>	
V <sub>IH</sub>	HIGH-Level Input Voltage	V <sub>CC</sub> = 1.65 V	1.3			1.3		1.3		V
		V <sub>CC</sub> = 2.0 V	1.5			1.5		1.5		V
		V <sub>CC</sub> = 4.5 V	3.15			3.15		3.15		V
		V <sub>CC</sub> = 5.5 V	3.85			3.85		3.85		V
V <sub>IL</sub>	LOW-Level Input Voltage	V <sub>CC</sub> = 1.65 V			0.4		0.4		0.4	V
		V <sub>CC</sub> = 2.0 V			0.5		0.5		0.5	V
		V <sub>CC</sub> = 4.5 V			1.35		1.35		1.35	V
		V <sub>CC</sub> = 5.5 V			1.65		1.65		1.65	V
V <sub>OH</sub>	HIGH-Level Output Voltage	V <sub>I</sub> = V <sub>IH</sub> or V <sub>IL</sub>								
		V <sub>CC</sub> = 1.65 V; I <sub>O</sub> = -20 μA	1.55			1.55		1.55		V
		V <sub>CC</sub> = 2.0 V; I <sub>O</sub> = -20 μA	1.9			1.9		1.9		V
		V <sub>CC</sub> = 4.5 V; I <sub>O</sub> = -20 μA	4.4			4.4		4.4		V
		V <sub>CC</sub> = 5.5 V; I <sub>O</sub> = -20 μA	5.4			5.4		5.4		V
		V <sub>CC</sub> = 4.5 V; I <sub>O</sub> = -4 mA	3.98			3.84		3.7		V
		V <sub>CC</sub> = 5.5 V; I <sub>O</sub> = -5.2 mA	4.98			4.84		4.7		V
V <sub>OL</sub>	LOW-Level Output Voltage	V <sub>I</sub> = V <sub>IH</sub> or V <sub>IL</sub>								
		V <sub>CC</sub> = 1.65 V; I <sub>O</sub> = 20 μA			0.1		0.1		0.1	V
		V <sub>CC</sub> = 2.0 V; I <sub>O</sub> = 20 μA			0.1		0.1		0.1	V
		V <sub>CC</sub> = 4.5 V; I <sub>O</sub> = 20 μA			0.1		0.1		0.1	V
		V <sub>CC</sub> = 5.5 V; I <sub>O</sub> = 20 μA			0.1		0.1		0.1	V
		V <sub>CC</sub> = 4.5 V; I <sub>O</sub> = 4 mA			0.26		0.33		0.4	V
		V <sub>CC</sub> = 5.5 V; I <sub>O</sub> = 5.2 mA			0.26		0.33		0.4	V
I <sub>I</sub>	Input Leakage Current	V <sub>CC</sub> = 5.5 V; V <sub>I</sub> = V <sub>CC</sub> or GND			±1		±1		±1	μA
I <sub>CC</sub>	Supply Current	V <sub>CC</sub> = 5.5 V; V <sub>I</sub> = V <sub>CC</sub> or GND I <sub>O</sub> = 0 A			5		10		20	μA
C <sub>I</sub>	Input Capacitance			5						pF

(1) Limits are 100% production tested at 25°C. Limits over the operating temperature range are ensured through correlations using statistical quality control (SQC) method.

(2) Typical values represent the most likely parametric norm as determined at the time of characterization. Actual typical values may vary over time and will also depend on the application and configuration.



## 8.5 Dynamic Characteristics

GND (ground = 0 V);  $C_L = 50$  pF unless otherwise specified

SYMBOL	PARAMETER	CONDITIONS	25°C			-40°C to +85°C		-40°C to +125°C		UNIT
			MIN	TYP	MAX	MIN	MAX	MIN	MAX	
$t_{pd}$	Propagation Delay	An to $\overline{Yn}$ ; see Figure 1 <sup>(1)</sup>								
		$V_{CC} = 1.65$ V		65	98		100		100	ns
		$V_{CC} = 2.0$ V		36	54		56		57	ns
		$V_{CC} = 4.5$ V		13	20		20		21	ns
		$V_{CC} = 5$ V; $C_L = 15$ pF		11						ns
		$V_{CC} = 5.5$ V		11	17		18		18	ns
		$\overline{En}$ to $\overline{Yn}$ ; see Figure 2								
		$V_{CC} = 1.65$ V		60	90		90		90	ns
		$V_{CC} = 2.0$ V		33	50		51		53	ns
		$V_{CC} = 4.5$ V		12	18		20		21	ns
		$V_{CC} = 5$ V; $C_L = 15$ pF		11						ns
		$V_{CC} = 5.5$ V		11	17		17		18	ns
$t_t$	Transition Time	see Figure 1 and Figure 2 <sup>(2)</sup>								
		$V_{CC} = 1.65$ V		31	47		48		48	ns
		$V_{CC} = 2.0$ V		16	24		26		27	ns
		$V_{CC} = 4.5$ V		7	11		19		22	ns
		$V_{CC} = 5.5$ V		6	13		16		19	ns
$C_{PD}$	Power Dissipation Capacitance	per gate; $V_I = \text{GND to } V_{CC}$ <sup>(3)</sup>		62					pF	

(1)  $t_{pd}$  is the same as  $t_{PLH}$  and  $t_{PHL}$

(2)  $t_t$  is the same as  $t_{TLH}$  and  $t_{THL}$

(3)  $C_{PD}$  is used to determine the dynamic power dissipation ( $P_D$  in  $\mu\text{W}$ ).

$P_D = C_{PD} \times V_{CC}^2 \times f_i \times N + \Sigma(C_L \times V_{CC}^2 \times f_o)$  where:

$f_i$  = input frequency in MHz;

$f_o$  = output frequency in MHz;

$C_L$  = output load capacitance in pF;

$V_{CC}$  = supply voltage in V;

$N$  = number of load switching outputs;

$\Sigma(C_L \times V_{CC}^2 \times f_o)$  = sum of the outputs.

## 9 Parameter Measurement Information

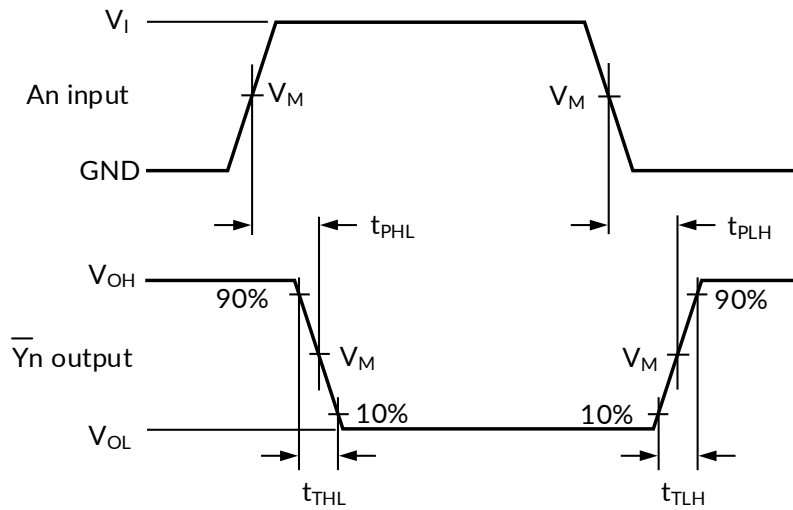

Figure 1. Propagation delay address input (An) to output ( $\bar{Y}_n$ ) and transition time output ( $\bar{Y}_n$ )

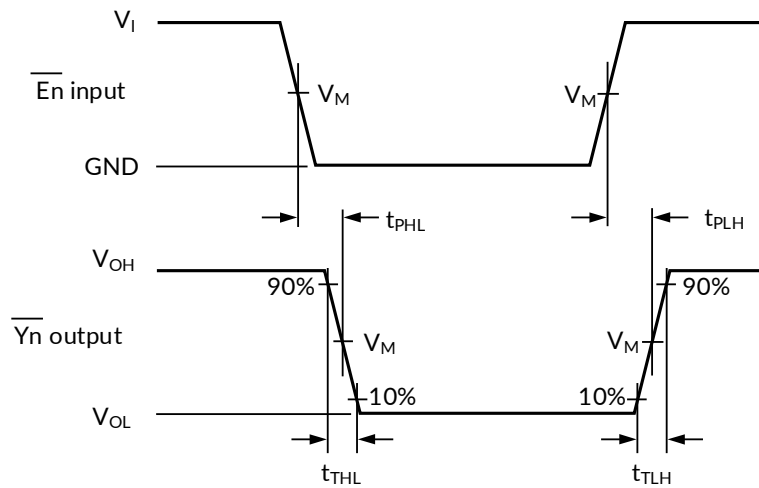
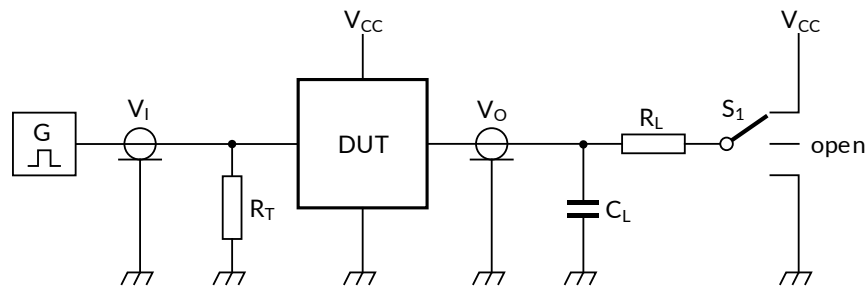
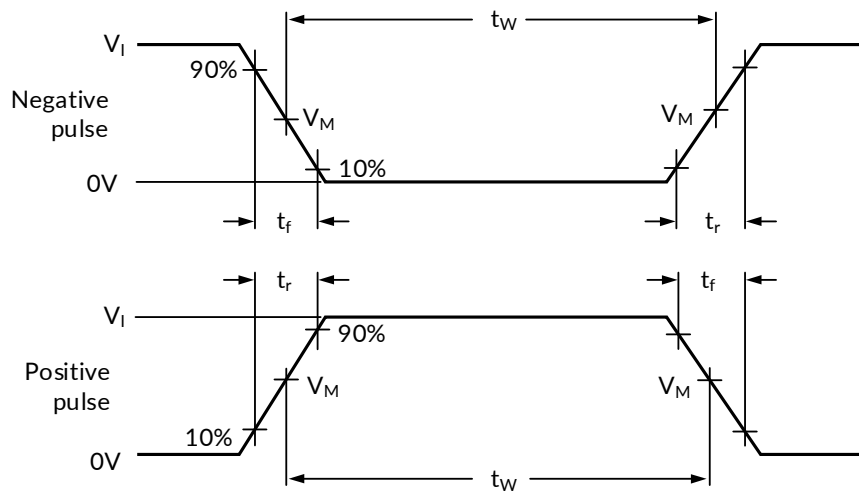

Figure 2. Propagation delay enable input ( $\bar{E}_n$ ) to output ( $\bar{Y}_n$ ) and transition time output ( $\bar{Y}_n$ )



Test data is given in Table 1.

Definitions for test circuit:

$R_T$  = Termination resistance; should be equal to output impedance  $Z_o$  of the pulse generator.

$C_L$  = Load capacitance including jig and probe capacitance.

$R_L$  = Load resistor.

$S_1$  = Test selection switch.

**Figure 3. Test circuit for measuring switching times**

**Table 1. Test data**

<b>S1 position</b>	<b>Input</b>		<b>Load</b>	
<b><math>t_{PHL}/t_{PLH}</math></b>	<b><math>V_I</math></b>	<b><math>t_r, t_f</math></b>	<b><math>C_L</math></b>	<b><math>R_L</math></b>
open	$V_{CC}$	6ns	15pF, 50pF	1k $\Omega$

# 10 PACKAGE OUTLINE DIMENSIONS

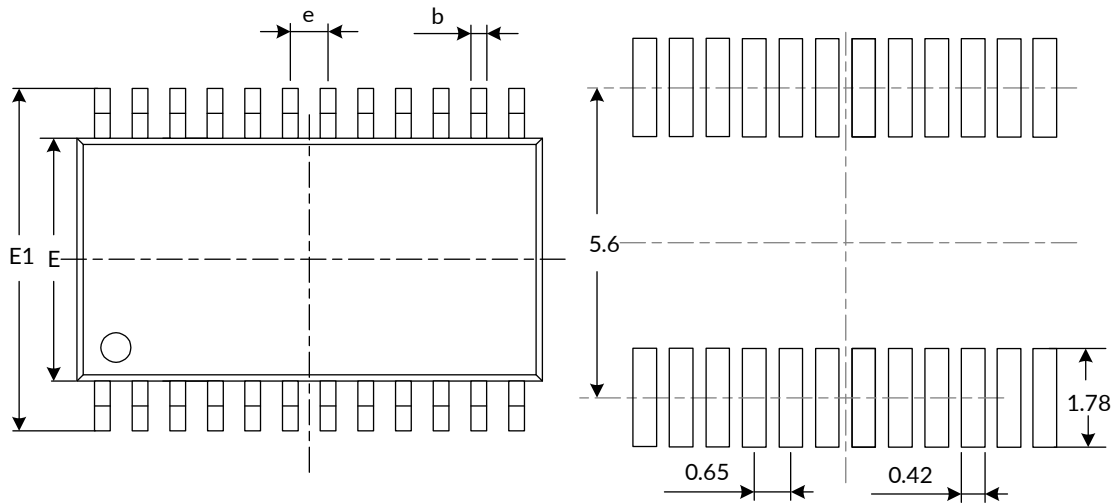
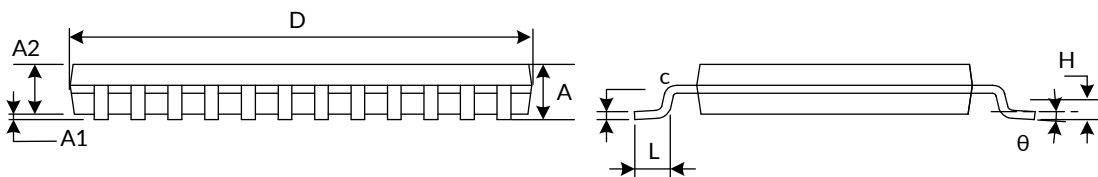
**TSSOP24<sup>(3)</sup>**

**RECOMMENDED LAND PATTERN (Unit: mm)**

Symbol	Dimensions In Millimeters		Dimensions In Inches	
	Min	Max	Min	Max
A <sup>(1)</sup>		1.200		0.047
A1	0.050	0.150	0.002	0.006
A2	0.800	1.050	0.031	0.041
b	0.200	0.290	0.008	0.011
c	0.130	0.170	0.005	0.007
D <sup>(1)</sup>	7.700	7.900	0.303	0.311
E <sup>(1)</sup>	4.300	4.500	0.169	0.177
E1	6.200	6.600	0.244	0.260
e	0.650 (BSC) <sup>(2)</sup>		0.026 (BSC) <sup>(2)</sup>	
L	0.450	0.750	0.018	0.030
H	0.250 (TYP)		0.010 (TYP)	
$\theta$	0°	8°	0°	8°

**NOTE:**

1. Plastic or metal protrusions of 0.15mm maximum per side are not included.
2. BSC (Basic Spacing between Centers), "Basic" spacing is nominal.
3. This drawing is subject to change without notice.

# 11 TAPE AND REEL INFORMATION

## REEL DIMENSIONS

## TAPE DIMENSION

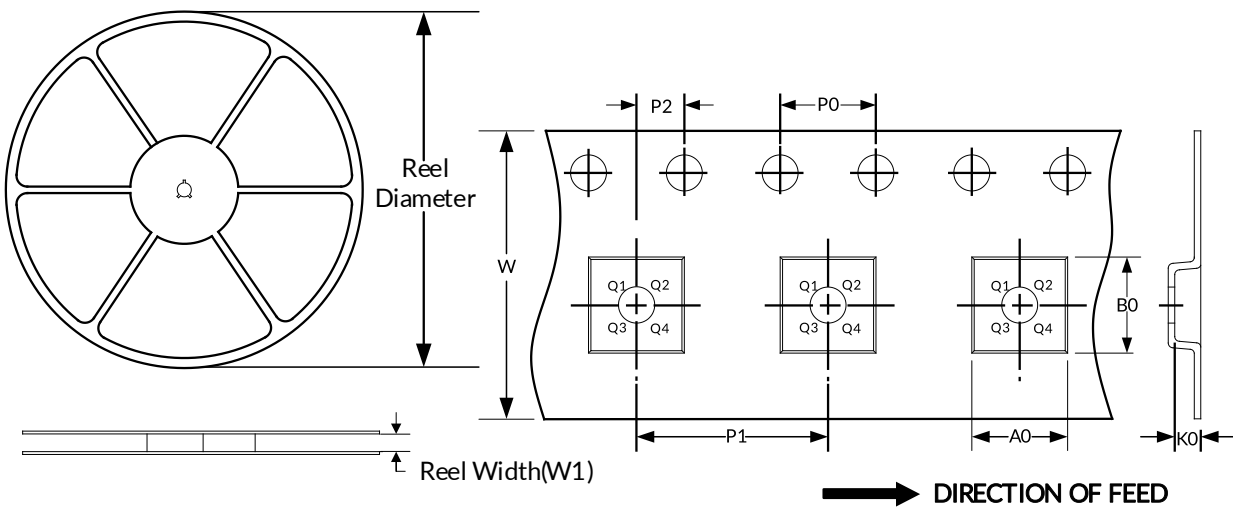

NOTE: The picture is only for reference. Please make the object as the standard.

### KEY PARAMETER LIST OF TAPE AND REEL

Package Type	Reel Diameter	Reel Width (mm)	A0 (mm)	B0 (mm)	K0 (mm)	P0 (mm)	P1 (mm)	P2 (mm)	W (mm)	Pin1 Quadrant
TSSOP24	13"	16.4	6.95	8.30	1.60	4.0	8.0	2.0	16.0	Q1

NOTE:

1. All dimensions are nominal.
2. Plastic or metal protrusions of 0.15mm maximum per side are not included.

## **IMPORTANT NOTICE AND DISCLAIMER**

Jiangsu Runic Technology Co., Ltd. will accurately and reliably provide technical and reliability data (including data sheets), design resources (including reference designs), application or other design advice, WEB tools, safety information and other resources, without warranty of any defect, and will not make any express or implied warranty, including but not limited to the warranty of merchantability Implied warranty that it is suitable for a specific purpose or does not infringe the intellectual property rights of any third party.

These resources are intended for skilled developers designing with Runic products You will be solely responsible for: (1) Selecting the appropriate products for your application; (2) Designing, validating and testing your application; (3) Ensuring your application meets applicable standards and any other safety, security or other requirements; (4) Runic and the Runic logo are registered trademarks of Runic Incorporated. All trademarks are the property of their respective owners; (5) For change details, review the revision history included in any revised document. The resources are subject to change without notice. Our company will not be liable for the use of this product and the infringement of patents or third-party intellectual property rights due to its use.